



100x200	300x300
200x100	100x100
200x200	400x200
200x300	300x400
300x200	400x300
	400x400







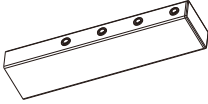
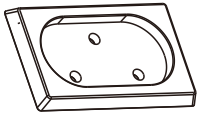
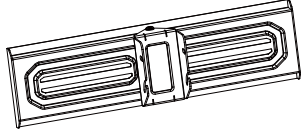

CAUTION: DO NOT EXCEED  
RATED LISTED WEIGHT. SERIOUS  
INJURY OR PROPERTY DAMAGE  
MAY OCCUR!

**XTR-TS1020**  
**XTR-TS1025**  
**XTR-TS1030**

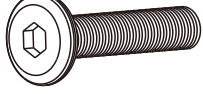

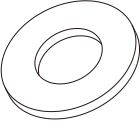
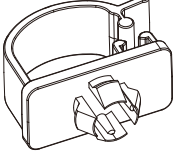



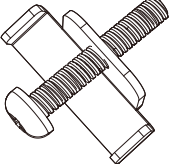



**PART LIST**

	<b>1</b> X2
	<b>2</b> X1
	<b>3</b> X1
	<b>4</b> X1
	<b>5</b> X1
	<b>6</b> X1

		Plastic Washer
		Steel Washer

	M6X45 <b>A</b> X3		<b>F</b> X5
	M6 x 16 x 1 <b>B</b> X7		<b>G</b> X2
	M6 x 18 x 1.5 <b>C</b> X3		<b>H</b> X1 4mm
	M6 x 12 <b>D</b> X8		<b>I</b> X1 10mm
	<b>E</b> X2		

**FOR TV INSTALLATION**

					
M4*12 <b>TV1</b> X4	M4*30 <b>TV1</b> X4	M6*16 <b>TV2</b> X4	M6*35 <b>TV3</b> X4	M8x25 <b>TV4</b> X4	M8x50 <b>TV5</b> X4
					
M5 <b>TV6</b> X4	M8 <b>TV7</b> X4	SP1 <b>TV8</b> X8	SP2 <b>TV9</b> X4	SP3 <b>TV10</b> X4	

3

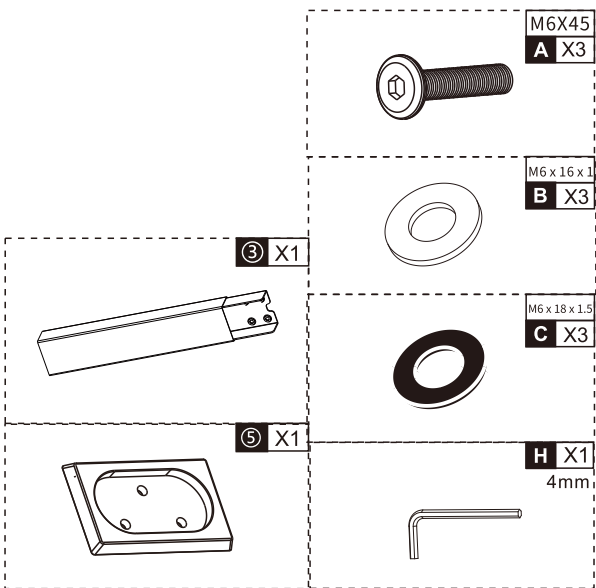
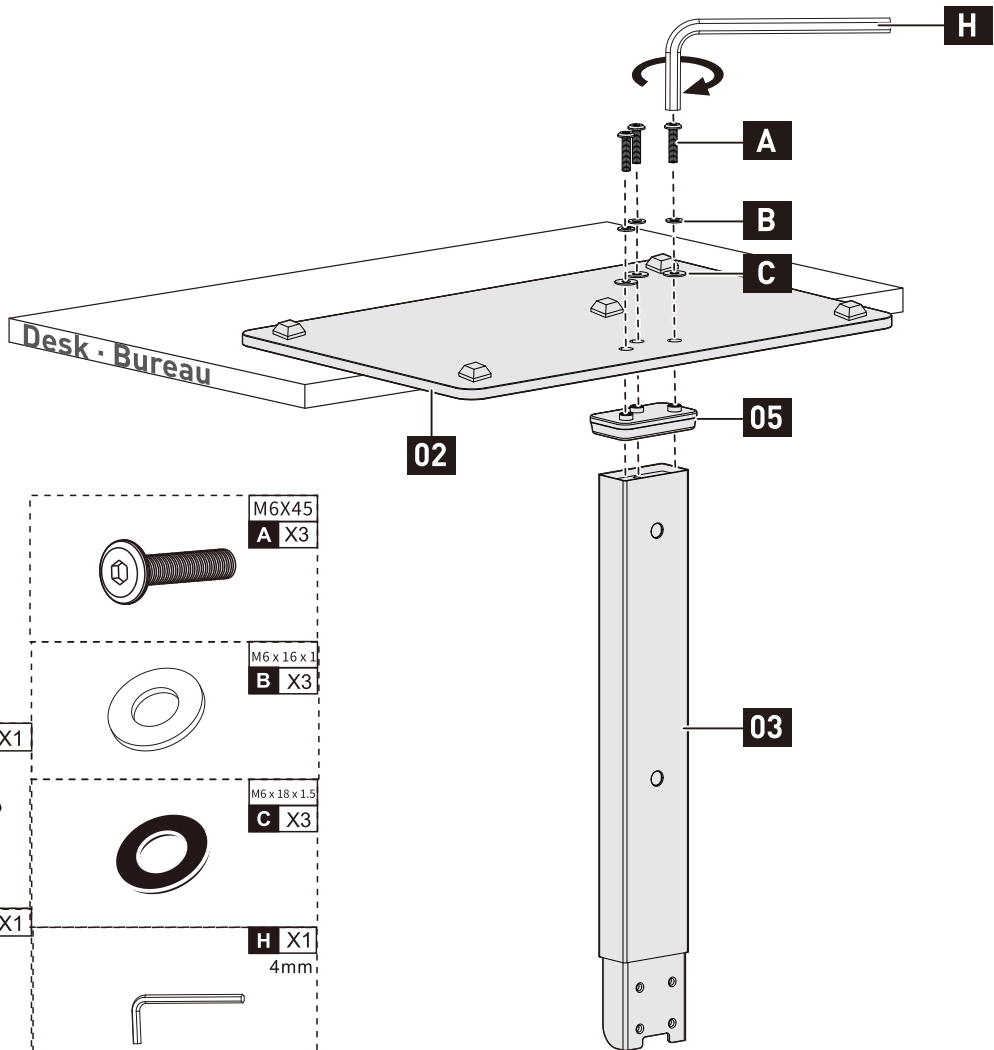
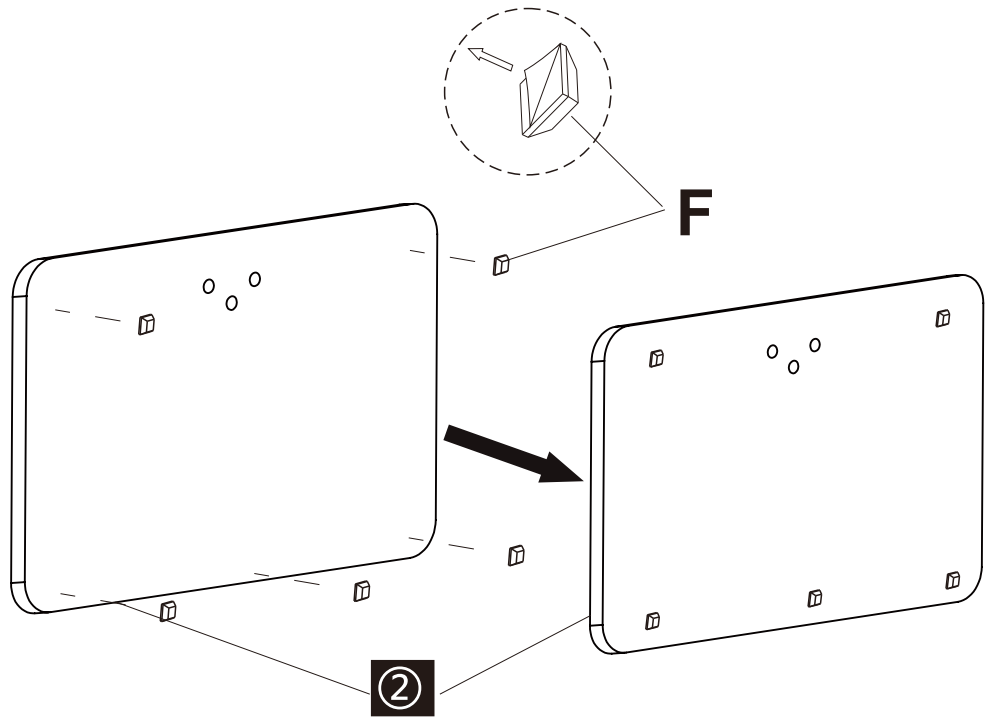
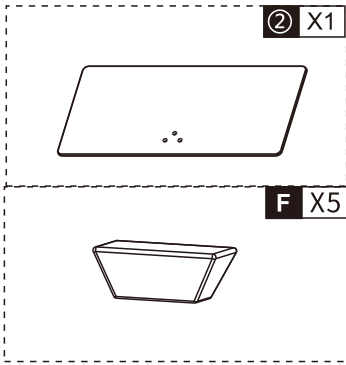

4

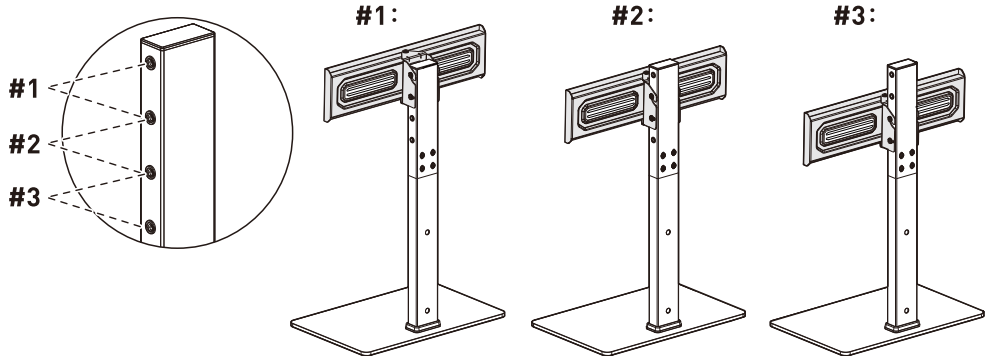
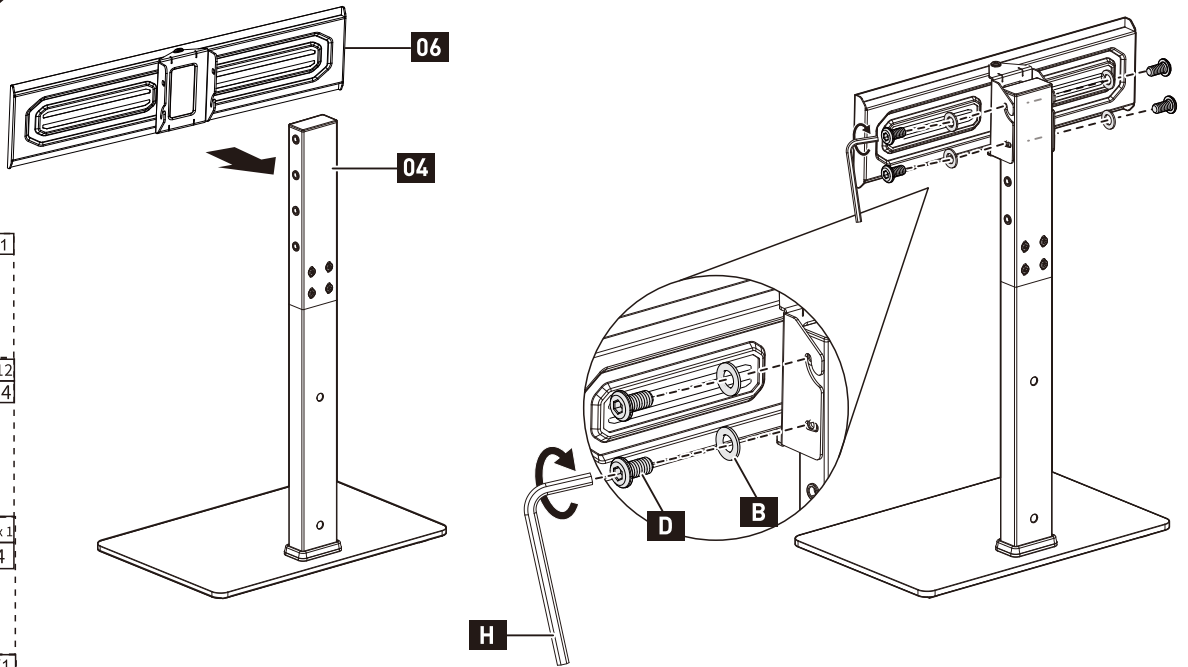
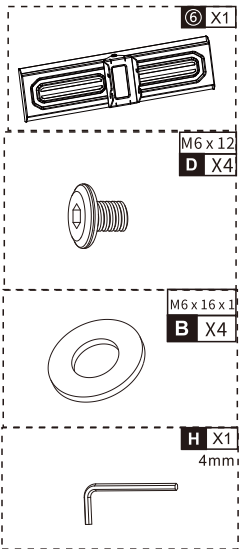
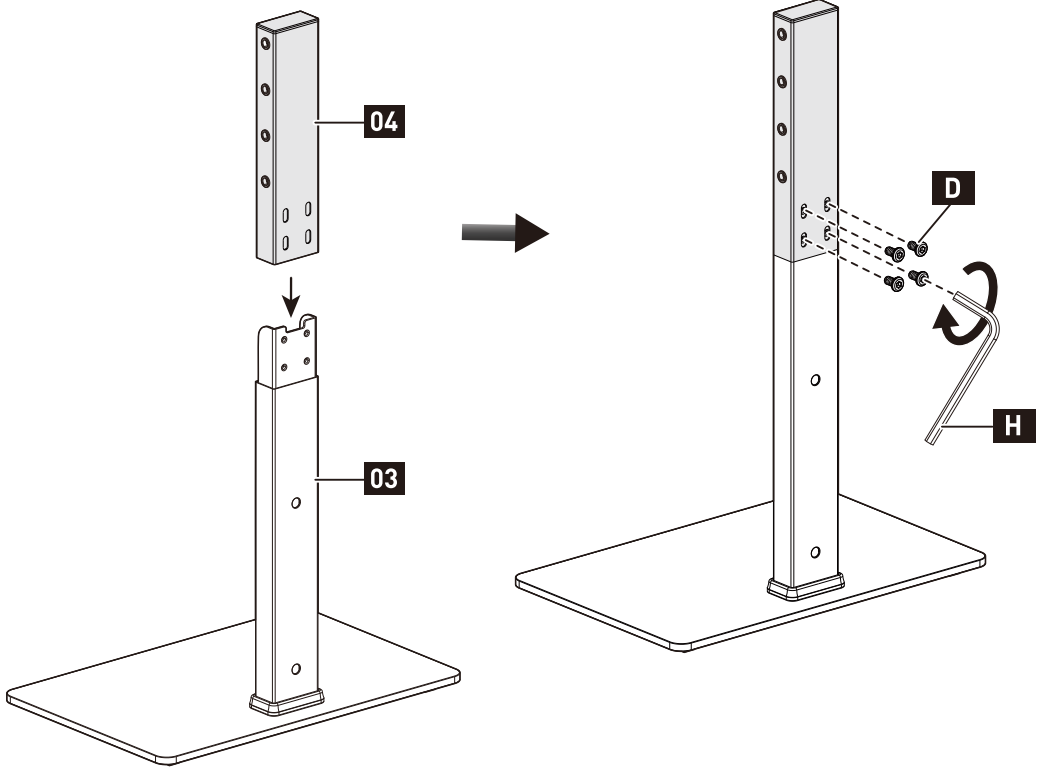
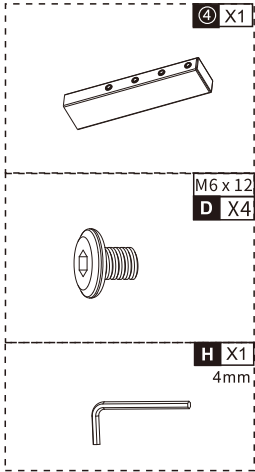

5

Swivel  
· Rotation

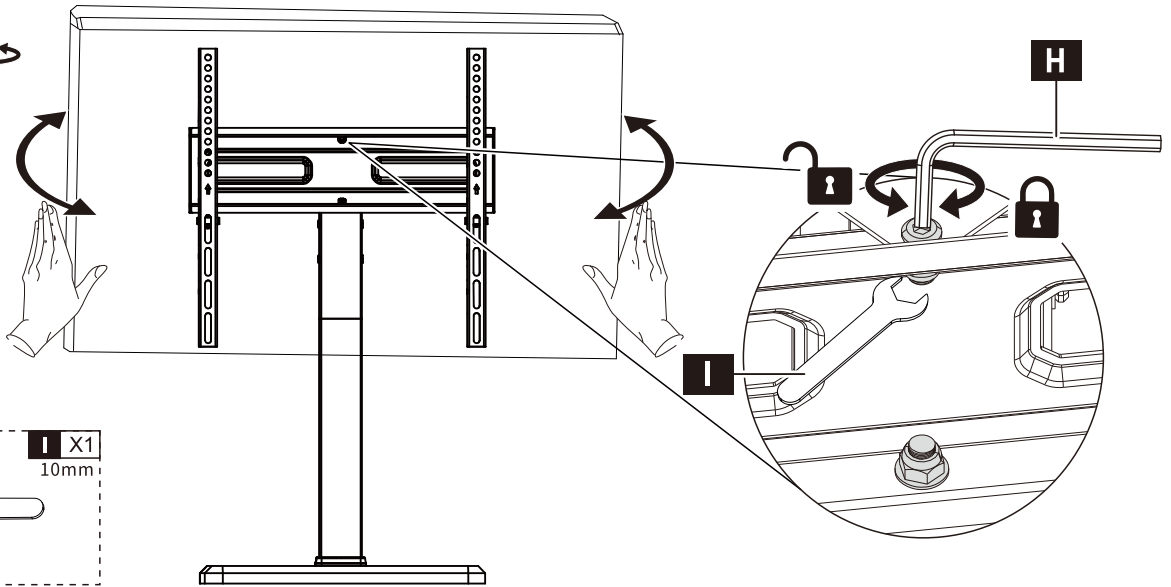

**I** X1  
10mm



**G** X2

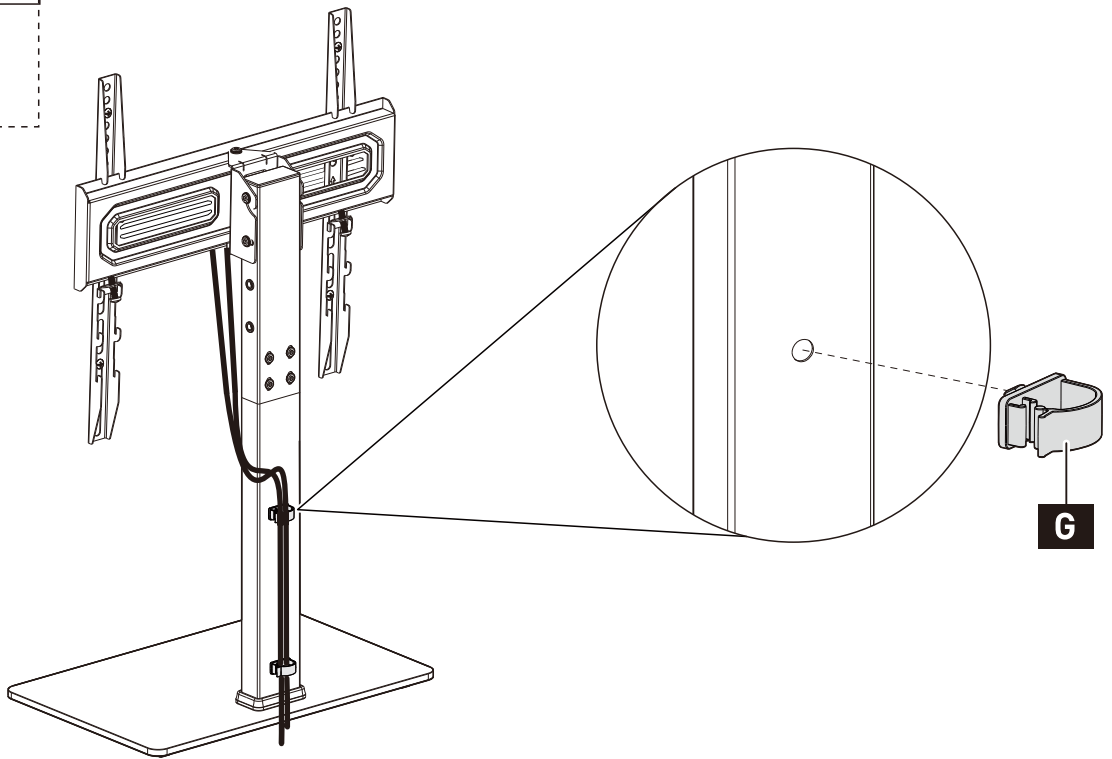
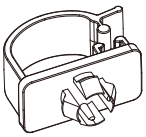

**G**

# 6

## Measure the TV fixing holes Width and Height

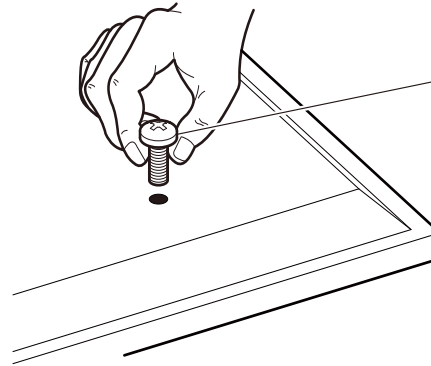
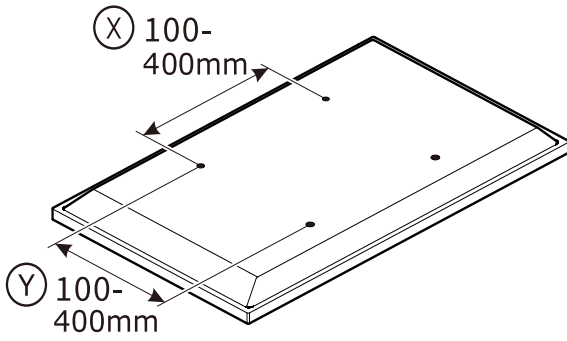

- M4 = TV1
- M6 = TV2-3
- M8 = TV4-5



If width (X) is greater than 600mm or height (Y) greater than 400mm STOP installation now and contact the customer help line

You are provided with 4 diameters of TV fixing screws, **M4**, **M6** and **M8**. Determine the screw diameter that fits.

**Spacers**

**SP**

For TVs with irregular/obstructed back

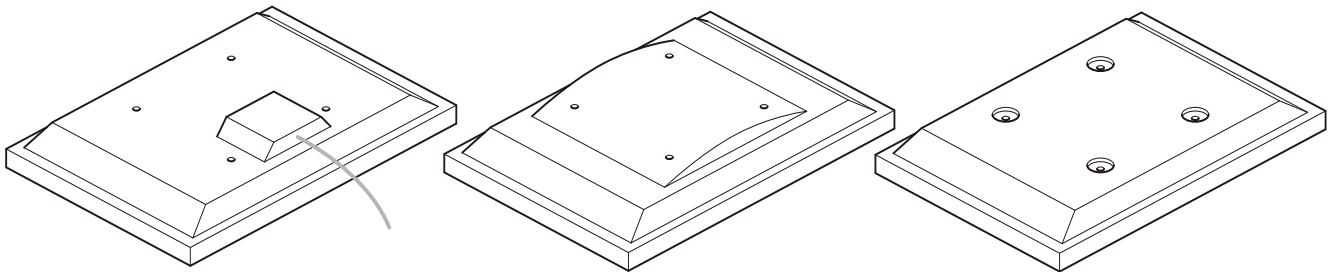

**No Spacers**

For TVs with flat/unobstructed back

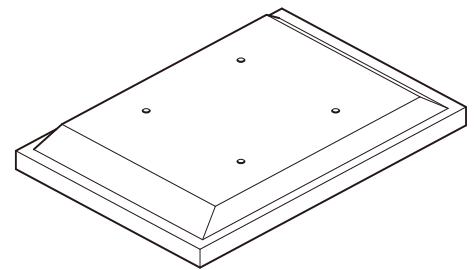

**WARNING**

please keep for future reference.

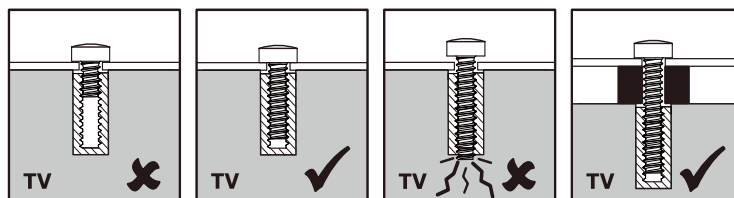

7

NOT INCLUDED

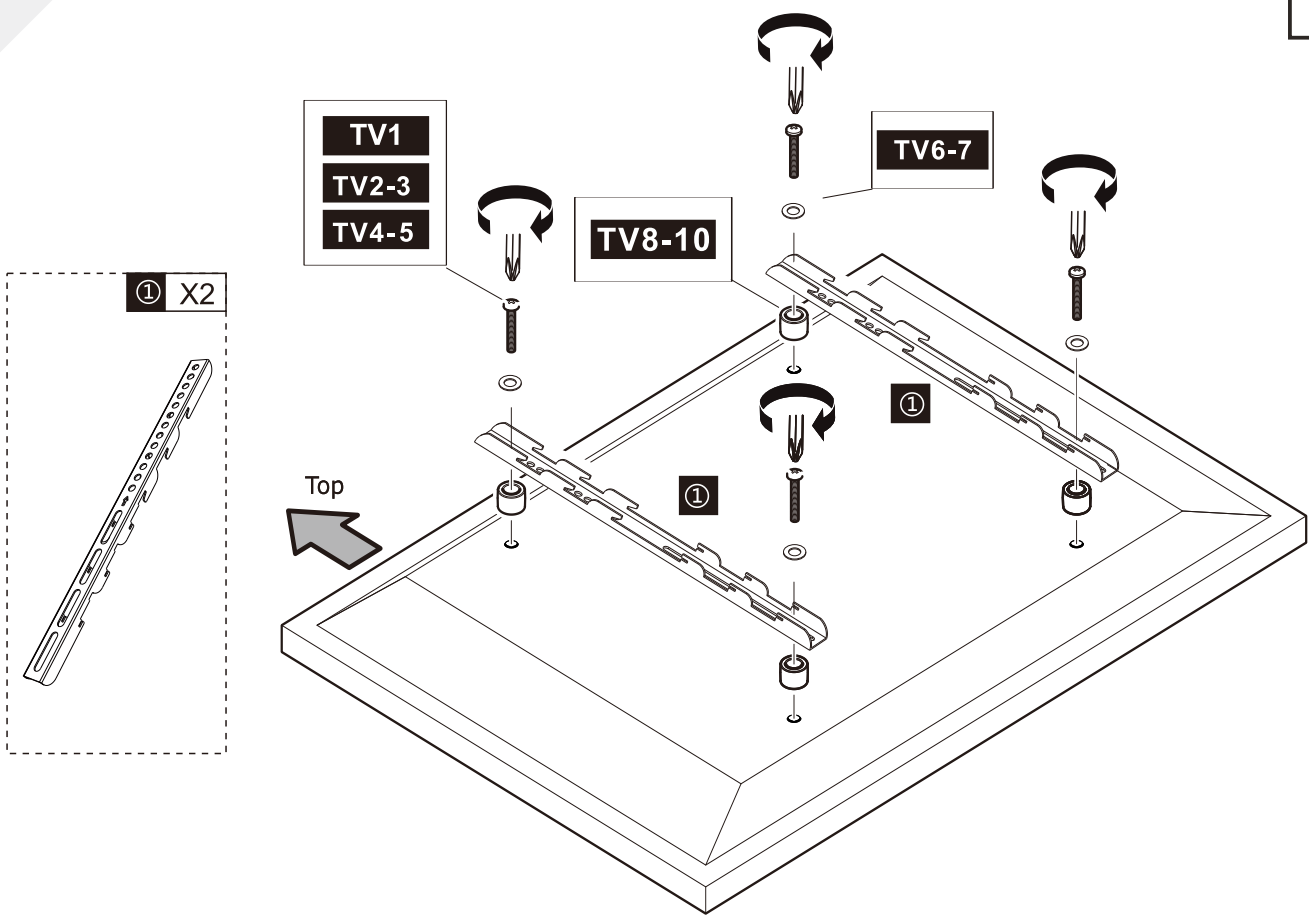

① X2

Top

TV1  
TV2-3  
TV4-5

TV8-10

TV6-7

M4  
TV1 X4

M6  
TV2-3 X4

M8  
TV4-5 X4

M5  
TV6 X4

M8  
TV7 X4

M8  
TV7 X4

SP1 - SP3  
TV8-10 X4

SP1 - SP3  
TV8-10 X4

SP1 - SP3  
TV8-10 X4

Attach the bracket to the back of your TV using suitable screw, reducer and spacer combinations.

7

NOT INCLUDED

